

## 305 SOLAR PANEL

EXCEPTIONAL EFFICIENCY AND PERFORMANCE

### BENEFITS

#### Highest Efficiency

Panel efficiency of 18.7% is higher than any commercially available competitor panel

#### More Power

SunPower 305 delivers 50% more power per unit area than conventional solar panels and 100% more than thin film solar panels

#### Reduces Installation Cost

More power per panel means fewer panels per install. This saves both time and money

#### Reliable and Robust Design

Proven materials, tempered front glass, and a sturdy anodized frame allow panel to operate reliably in multiple mounting configurations



**The SunPower 305 Solar Panel provides today's highest efficiency and performance.** Utilizing 96 next generation SunPower all-back contact solar cells, the SunPower 305 delivers an unprecedented total panel conversion efficiency of 18.7%. The 305 panel's reduced voltage-temperature coefficient and exceptional low-light performance attributes provide outstanding energy delivery per peak power watt.

#### SunPower's High Efficiency Advantage - Up to Twice the Power

Comparable systems covering 1000 m <sup>2</sup> / 10,750 ft <sup>2</sup>			
	Thin Film	Conventional	SunPower
Watts / Panel	65	165	305
Efficiency	9.0%	12.0%	18.7%
kWs	90	120	187

#### Electrical Data

Measured at Standard Test Conditions (STC): irradiance of 1000/m<sup>2</sup>, air mass 1.5 g, and cell temperature 25° C

Peak Power (+/-5%)	Pmax	305 W
Rated Voltage	Vmp	54.7 V
Rated Current	Imp	5.58 A
Open Circuit Voltage	Voc	64.2 V
Short Circuit Current	Isc	5.96 A
Maximum System Voltage	IEC, UL	1000 V, 600 V
Temperature Coefficients		
	Power	-0.38% / °C
	Voltage (Voc)	-176.6 mV/°C
	Current (Isc)	3.5 mA/°C
Series Fuse Rating		15 A
Peak Power per Unit Area		187 W/m <sup>2</sup> , 17.4 W/ft <sup>2</sup>
CEC PTC Rating		282.1 W

#### Mechanical Data

Solar Cells	96 SunPower all-back contact monocrystalline
Front Glass	4.0 mm (5/32 in) tempered
Junction Box	IP-65 rated with 3 bypass diodes
Output Cables	900 mm length cables / Multi-Contact connectors
Frame	Clear anodized aluminum alloy type 6063
Weight	24 kg, 53 lbs

#### IV Curve

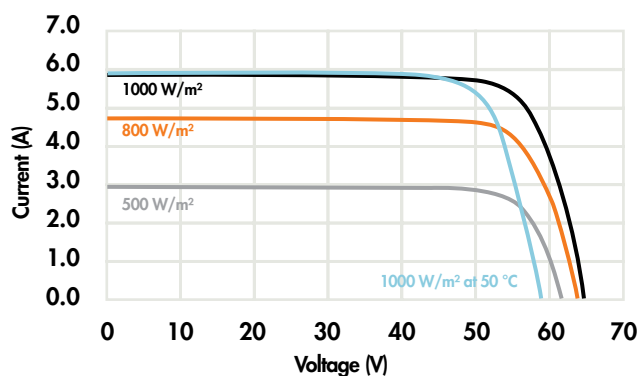

Current/voltage characteristics with dependence on irradiance and module temperature.

#### Tested Operating Conditions

Temperature	-40° C to +85° C (-40° F to +185° F)
Max load	50 psf (2400 Pascals) front and back
Impact Resistance	Hail - 25mm (1 in) at 23 m/s (52 mph)

#### Warranty and Certifications

Warranty	25 year limited power warranty
	5 year limited product warranty
Certifications	IEC 61215 , Safety tested IEC 61730; UL listed (UL 1703), Class C Fire Rating

#### Dimensions

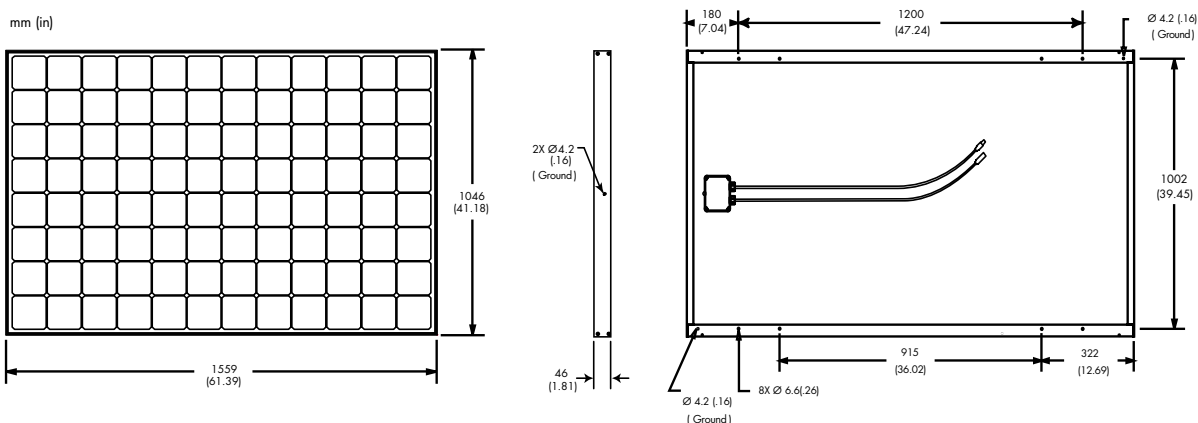

**CAUTION: READ SAFETY AND INSTALLATION INSTRUCTIONS BEFORE USING THE PRODUCT.** Go to [www.sunpowercorp.com/panels](http://www.sunpowercorp.com/panels) for details

#### About SunPower

SunPower designs, manufactures and delivers high-performance solar electric technology worldwide. Our high-efficiency solar cells generate up to 50 percent more power than conventional solar cells. Our high-performance solar panels, roof tiles and trackers deliver significantly more energy than competing systems.